

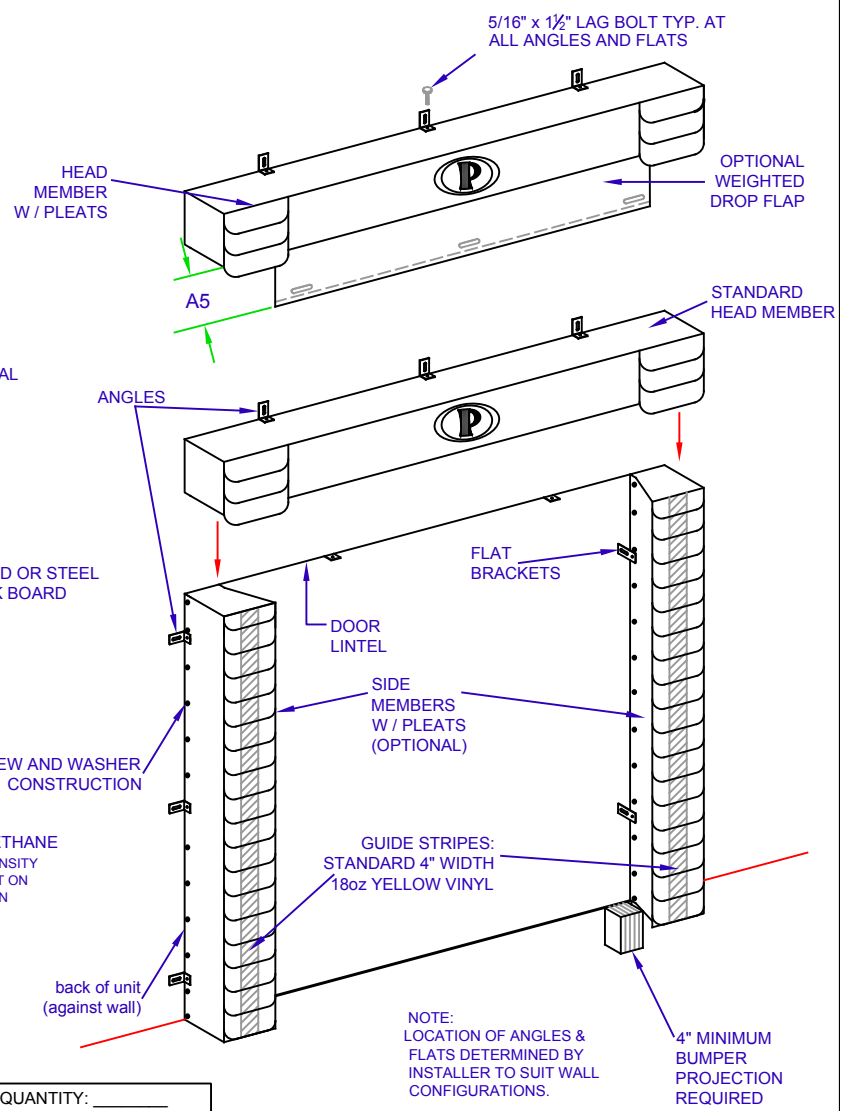

# PERMA ORIGINAL DOCK SEAL: FOAM HEADER

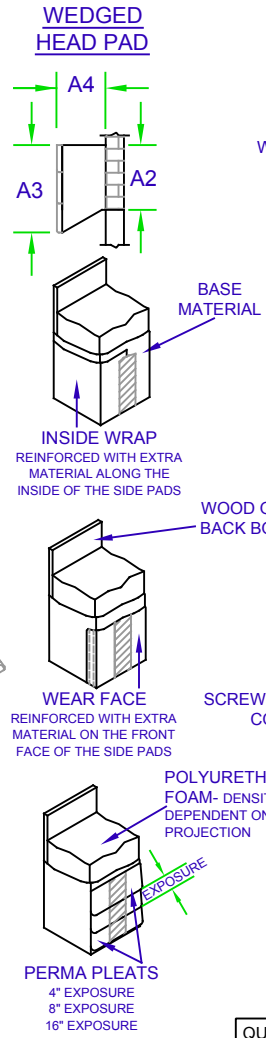
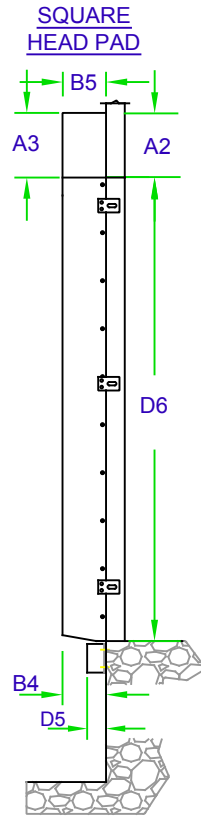
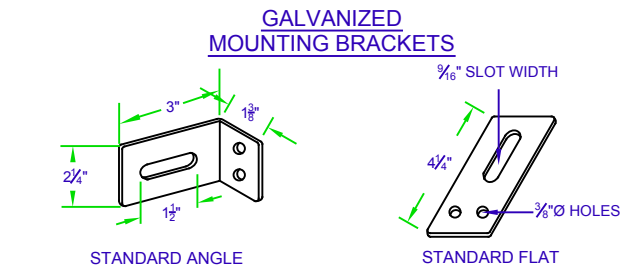
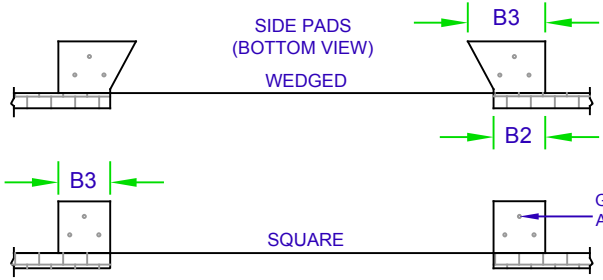
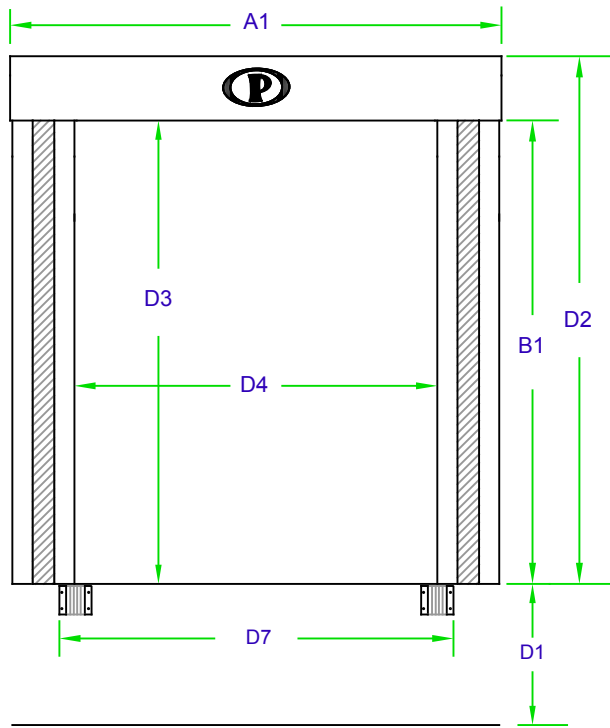

<b>QUANTITY:</b> _____		
<b>DIMS.</b> A1- _____ " LENGTH A2- _____ " HEIGHT AT REAR A3- _____ " HEIGHT AT FACE A4- _____ " PROJECTION A5- _____ " DROP FLAP	<b>HEAD PAD DATA:</b> BACK BOARD- W: <input type="checkbox"/> S: <input type="checkbox"/> MATERIAL- _____ DROP FLAP: <input type="checkbox"/> PERMA PLEATS: <input type="checkbox"/> PLEAT MATERIAL- _____ EXPOSURE- _____ "	<b>GENERAL INFO:</b> APPROACH- DECLINE: <input type="checkbox"/> INCLINE: <input type="checkbox"/> LEVEL: <input type="checkbox"/> DIMS. D1- _____ " DOCK HEIGHT FROM GROUND D2- _____ " ENTIRE UNIT HEIGHT D3- _____ " INSIDE OPENING HEIGHT D4- _____ " INSIDE OPENING WIDTH D5- _____ " BUMPER PROJ. D6- _____ " DOOR HEIGHT D7- _____ " DOOR WIDTH
<b>DIMS.</b> B1- _____ " LENGTH B2- _____ " WIDTH AT REAR B3- _____ " WIDTH AT FACE B4- _____ " PROJ. AT BOTTOM B5- _____ " PROJ. AT TOP	<b>SIDE PAD DATA:</b> BACK BOARD- W: <input type="checkbox"/> S: <input type="checkbox"/> MATERIAL- _____ WEAR FACE: <input type="checkbox"/> INSIDE WRAP: <input type="checkbox"/> PERMA PLEATS: <input type="checkbox"/> PLEAT MATERIAL- _____ EXPOSURE- _____ "	<div style="text-align: center;">  <b>PERMA TECH, INC.</b>                  363 HAMBURG STREET • BUFFALO, NY 14204                  (716) 854-0707 • 1-800-DOC-SEAL  <a href="http://www.permatechinc.com">www.permatechinc.com</a> </div>
<b>SPECIAL INFORMATION:</b> _____		<b>JOB:</b> _____
<b>DEALER:</b> _____		<b>DATE:</b> _____
<b>CONTACT:</b> _____		<b>QUOTE #:</b> _____
<b>APPROVED BY SIGNATURE:</b> _____		